



(PA-EP-SC Module shown installed on TM Meter;
module can be installed on all FLOMEC meters with Q9 display)

Pulse Access, External Power & Scaled Pulse Module

FOR USE WITH ALL TURBINE METERS WITH Q9 DISPLAY

Please save these instructions for future reference. Read carefully before attempting to assemble, install, operate or maintain the product described.

Protect yourself and others by observing all safety information. Failure to comply with instructions could result in personal injury and/or property damage.

Please refer to back cover for information regarding this product's warranty and other important information.

DO NOT RETURN THIS PRODUCT TO THE STORE!

Please contact Great Plains Industries, Inc.® before returning any product. If you are missing parts, or experience problems with your installation, contact our Customer Support Department. We will be happy to assist you.

Call: 888-996-3837 or 316-686-7361

Email: meters@tplains.com

SAVE FOR YOUR RECORDS

Model #: _____

Serial #: _____

Purch. Date: _____

BEFORE YOU BEGIN

Usage Requirements

- This Pulse Access, External Power & Scaled Pulse module is not FM Approved. Therefore, use of this module with an approved metering system voids FM Approval.
- This module requires an input power of 5.0 - 26 VDC (24 VDC is recommended). The DC signal will power the meter electronics, leaving batteries as backup for the meter electronics.
- This module is designed for use with all meters that are equipped with the Q9 display option. The PA-EP-SC module can be field calibrated through the configuration menu options on the Q9 display.

UNPACKING/INSPECTION

Inspect

- After unpacking the unit, inspect carefully for any damage that may have occurred during transit. Check for loose, missing or damaged parts. Shipping damage claims must be filed with carrier.
- See General Safety Instructions, and all Cautions, Warnings, and Dangers as shown.



SPECIFICATIONS

Pulse Access, External Power & Scaled Pulse Module	
Mechanical	
Housing material:	Nylon 6/6
Strain relief:	Hubble PG7. Grip range 0.11-0.26
Housing port thread:	Female 1/2-20 UNF-2B (Compatible with PG7)
Cable:	Belden 9363 (22 AWG-3 conductor with drain wire and shield)
Cable length:	10 ft (3m), provided
Operation temperature:	0° to +140°F (-18° to +60°C)
Storage temperature:	-40° to +180°F (-40° to +82°C)
Power:	
Voltage minimum:	5.0 VDC
Voltage maximum:	26 VDC
Isolated:	No
Pulse Output:	
Type:	Open Collector (NPN)
*External Pull Up Voltage	5.0 to 26 VDC
**Internal Pull Up Voltage	5.0 to 26 VDC

* Note: Customer supplied external voltage with separate power supply and a minimum external pull up resistance of 820 ohms.

** Note: When configured for internal pull up resistor, no external pull up resistor is required. Internal pull up is fixed at 100K ohm.

GETTING STARTED

SAFETY / SPECIFICATIONS

ASSEMBLY / INSTALLATION

OPERATION

TROUBLESHOOTING

MAINTENANCE / REPAIR

SPECIFICATIONS (CONTINUED)

Dimensions	Length (A)	Height (B)	Width (C)	Strain Relief (D)
PA-EP-SC Module	3.45 in. (88 mm)	0.90 in. (23 mm)	2.18 in. (55 mm)	0.86 in. (22 mm)

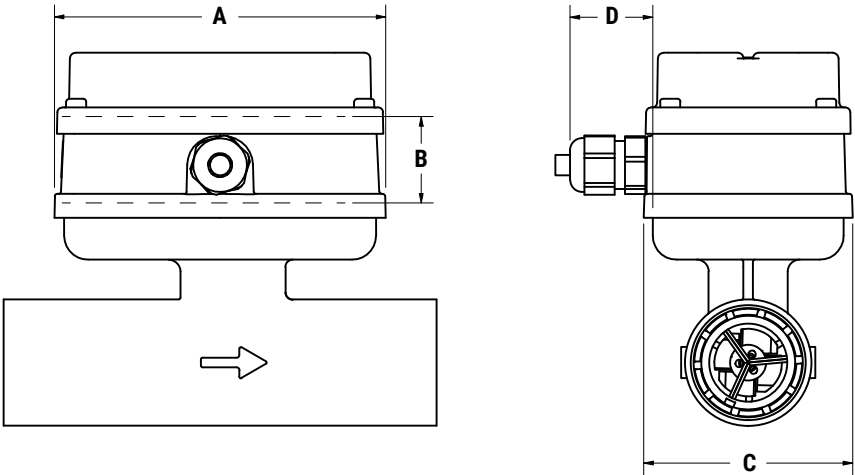

Figure 1

(PA-EP-SC Module shown installed on TM Meter; module can be installed on all FLOMEC meters with Q9 display)

INSTALLATION

Installing Module

1. Remove the display electronics from the front of the turbine.
- NOTE:** If you are installing more than one module at a time, take care to keep the proper electronics paired with the original turbine.
2. Disconnect 2-pin coil connector from display. Make sure coil remains firmly attached to meter body (DO NOT pull on wires or attempt to remove from meter body).
 3. Connect the module to the 10-pin connector located on the back side of the computer electronics (see Figure 2).

4. Reconnect the coil connector to the 2-pin terminal block on the other end of the computer backside. Once the cables are installed on the display, the housing of the display can be placed on top of the module (see Figure 2).
5. Remove the AAA batteries from the display if using external power to enable the scaled pulse output feature. If only the raw pulse output is being used, the batteries can remain installed and will provide a battery backup if the meter loses external power.

NOTE: The scaled pulse feature is only enabled on the Q9 configuration menu if the batteries are removed and external power is applied.

6. Install the computer electronics to the front side of the turbine. Tighten the four screws snugly.

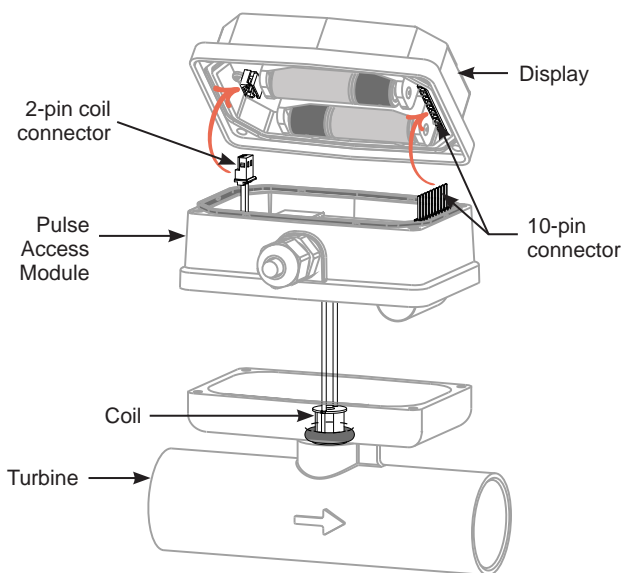

Figure 2

INSTALLATION (CONTINUED)

Wiring

1. The Pulse Access module comes pre-wired for external connections to external power and provides an open collector output which can be set to either raw or scaled pulse output. The wires are color coded to be connected as shown in Figures 3 & 4.

Wire Color	Feature	Wire Color	Feature
Red	VCC	White	Pulse Out
Black	GND		

NOTE: The pulse output is set to raw pulse output as the default setting on the Q9 display. If your application requires a scaling of the pulse output refer to the installation instructions to enable the scaled pulse feature and refer to the Q9 owner's manual for instructions on the configuration of the scaled pulse feature.

NOTE: If using the scaled pulse output feature use the scaled K-factor in the user interface device.

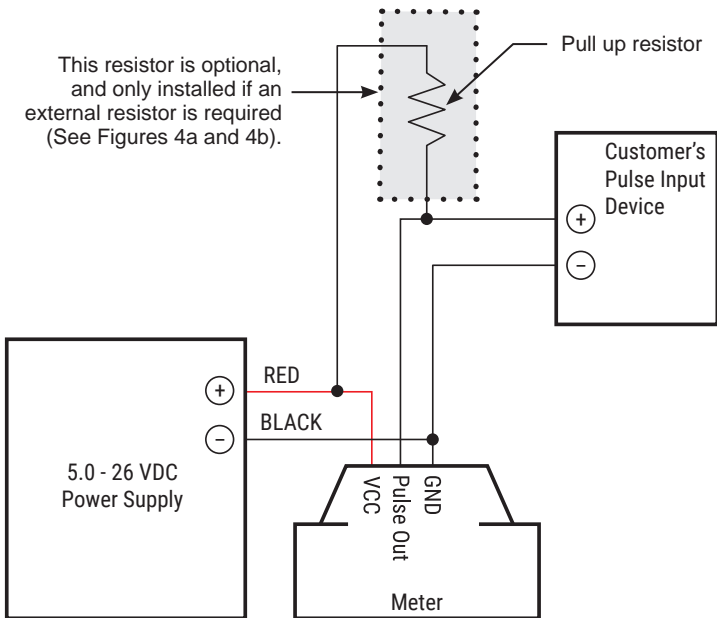
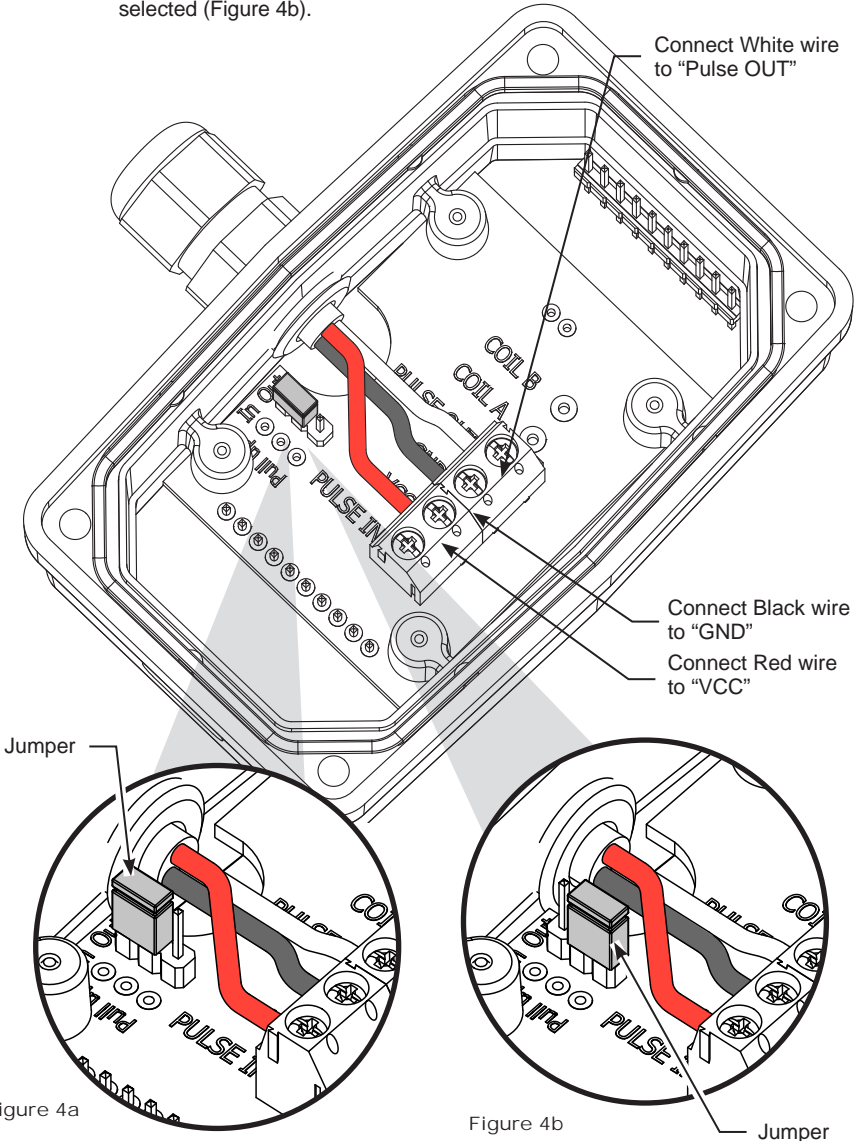

Figure 3

INSTALLATION (CONTINUED)

Wiring (Continued)

NOTE: The internal and external options for the pull up resistance and voltage is selectable by the header on the pulse access board (see Figures 4a & 4b). When the Jumper is on the top two pins, the 'external resistor required' option is selected (Figure 4a). This external resistor can be installed as shown on Figure 3, but could also be installed as shown on Figure 3, but could also be built into the existing customer equipment. When the Jumper is located on the bottom two pins, the 'internal resistor' option is selected (Figure 4b).



OPERATION / CALIBRATION

Adjusting Scaled Pulse Kfactor

1. To set or adjust Scaled Pulse Kfactor settings, refer to the Q9 Owner's Manual (Non-Agency) Field Calibration Section for further instructions (see below).

You can download the Q9 Owner's Manual (Non-Agency) here:



or visit [FLOMECmeters.com](https://www.flovecmeters.com) to download owner's manuals and other technical documents.

TROUBLESHOOTING

Symptom	Possible Cause(s)	Corrective Action
A. No output signal	<ol style="list-style-type: none">1. Incorrect or no input power2. Not wired correctly3. Broken connection4. Defective PC board connector5. Defective unit	<ol style="list-style-type: none">1. Supply correct power requirements2. Check Owner's manual for correct installation3. Check resistance to determine location of break4. Contact distributor or factory for replacement5. Contact distributor or factory for replacement

PARTS LIST

Part Number	Description
901002-52	O-ring

PARTS & SERVICE

For warranty consideration, parts, or other service information, please contact your local distributor. If you need further assistance, contact the GPI Product Support Department in Wichita, Kansas, during normal business hours.

A toll free number is provided for your convenience.

1-888-996-3837

To obtain prompt, efficient service, always be prepared with the following information:

- The model number of your meter.
- The serial number or manufacturing date code of your meter.
- Part descriptions and numbers.

For warranty work, always be prepared with your original sales slip or other evidence of purchase date.

IMPORTANT: Please contact GPI before returning any parts. It may be possible to diagnose the trouble and identify needed parts in a telephone call.

CAUTION

Do not return this product without prior approval from the GPI Product Support Department. Due to strict government regulations, GPI cannot accept parts unless they have been drained and cleaned.

WEEE DIRECTIVE



The Waste Electrical and Electronic Equipment (WEEE) directive (2002/96/EC) was approved by the European Parliament and the Council of the European Union in 2003. This symbol

indicates that this product contains electrical and electronic equipment that may include batteries, printed circuit boards, liquid crystal displays or other components that may be subject to local disposal regulations at your location. Please understand those regulations and dispose of this product in a responsible manner.

FLOMEC® TWO-YEAR LIMITED WARRANTY

Great Plains Industries, Inc. 5252 E. 36th Street North, Wichita, KS USA 67220-3205, hereby provides a limited warranty against defects in material and workmanship on all products manufactured by Great Plains Industries, Inc. This product includes a 2 year warranty. Manufacturer's sole obligation under the foregoing warranties will be limited to either, at Manufacturer's option, replacing or repairing defective Goods (subject to limitations hereinafter provided) or refunding the purchase price for such Goods theretofore paid by the Buyer, and Buyer's exclusive remedy for breach of any such warranties will be enforcement of such obligations of Manufacturer. The warranty shall extend to the purchaser of this product and to any person to whom such product is transferred during the warranty period.

The warranty period shall begin on the date of manufacture or on the date of purchase with an original sales receipt. This warranty shall not apply if:

A. the product has been altered or modified outside the warrantor's duly appointed representative;

B. the product has been subjected to neglect, misuse, abuse or damage or has been installed or operated other than in accordance with the manufacturer's operating instructions.

To make a claim against this warranty, contact the GPI Customer Service Department at

316-686-7361 or 888-996-3837.

Or by mail at:

Great Plains Industries, Inc.

5252 E. 36th St. North

Wichita, KS, USA 67220-3205

The company will step you through a product troubleshooting process to determine appropriate corrective actions.

GREAT PLAINS INDUSTRIES, INC., EXCLUDES LIABILITY UNDER THIS WARRANTY FOR DIRECT, INDIRECT, INCIDENTAL AND CONSEQUENTIAL DAMAGES INCURRED IN THE USE OR LOSS OF USE OF THE PRODUCT WARRANTED HEREUNDER.

The company herewith expressly disclaims any warranty of merchantability or fitness for any particular purpose other than for which it was designed.

This warranty gives you specific rights and you may also have other rights which vary from U.S. state to U.S. state.

Note: In compliance with MAGNUSON MOSS CONSUMER WARRANTY ACT – Part 702 (governs the resale availability of the warranty terms).

Wichita · Sydney

GREAT PLAINS INDUSTRIES



© 2020 Great Plains Industries, Inc., All Rights Reserved.

Great Plains Industries, Inc. / 888-996-3837 / FLOMECmeters.com